

# OWNERS MANUAL FOR



**WHITE**  
**BROTHERS**  
CYCLING

580 N. Westgate Dr.  
Grand Junction, CO 81505 USA  
1.800.999.8277  
[www.whitebrotherscycling.com](http://www.whitebrotherscycling.com)

*A division of*

 **EKO** SPORT, INC.  
TM

# TABLE OF CONTENTS

APPLICATIONS.....	PAGE 3
FORK INSTALLATION.....	PAGE 3
TUNING.....	PAGE 4
MAINTENANCE.....	PAGE 5
EXPLODED VIEWS.....	PAGE 6
WARRANTY.....	PAGE 7

## SAFETY

1.) NEVER REMOVE STEER TUBE FROM CROWN. THIS IS A PRESSED IN PART. REMOVING IT WILL RENDER BOTH THE CROWN AND STEERER INOPERABLE. \* MAKE SURE THE FORK CAPS AND ALL FORK HARDWARE (brake studs, pinch bolts, etc.) ARE TIGHT.

2.) DO NOT PERFORM ANY MODIFICATIONS OR ADJUSTMENTS THAT ARE NOT OUTLINED IN THIS MANUEL. SEE THE TUNING SECTION FOR MORE DETAILS.

3.) INSPECT YOUR FORK BEFORE EVERY RIDE. INSPECT THE CROWN, TUBES, AND AXLE SEAT AREAS FOR ANY SIGNS OF FATIGUE, BENDING, CRACKING OR OTHER DAMAGE. IF YOU NOTICE ANY TYPE OF DAMAGE, DO NOT RIDE IT. RETURN IT TO YOUR DEALER FOR A COMPLETE INSPECTION AND NECESSARY REPAIR OR WARRANTY STEPS. PLEASE REFER TO THE WARRANTY SECTION OF THIS MANUAL.

4.) PERFORM ALL RECOMMENDED MAINTENANCE ACCORDING TO THE MAINTENANCE SECTION OF THIS MANUAL. FAILURE TO PERFORM MAINTENANCE COULD DRASTICALLY REDUCE THE FORKS LIFE AND PERFORMANCE.

5.) WHITE BROTHERS RECOMMENDS THAT YOU WEAR PROPER SAFETY EQUIPMENT EVERY TIME YOU RIDE, INCLUDING A APPROVED BICYCLE HELMET. NEVER RIDE AT NIGHT WITHOUT LIGHTS.

*\*IF SERVICE BECOMES NECESSARY OR REMOVAL OCCURS, PLEASE CALL WHITE BROTHERS CUSTOMER SERVICE FOR PRODUCT EVALUATION AND DIAGNOSIS.*

## INTRODUCTION

Thanks for purchasing your new White Brothers fork. Our forks are designed so you can perform at your absolute peak. Your new White Brothers fork has air damping and is air sprung for light weight performance. The air spring and damper is set stock to satisfy a wide range of rider weights and riding styles. Fine tuning can be easily accomplished by changing air pressure in the air spring cartridges. See the adjustment and maintenance section for rider weight verses air pressures settings. For very heavy or very light riders the damper adjustor can be replaced with various adjustor sizes to give a wide range of damping. Steering accuracy is improved over conventional MTB forks by utilizing superior materials and design. These include oversized 31.75mm fork tubes, a torsion box design steering crown with pressed in tubes, a one piece billet brake arch and extra thick drop-outs. The WB forks bootless design allows a considerable amount more slider/stanchion overlap than competitor forks which attributes to fork steering accuracy. Fork travel has been chosen to offer the best performance possible for each forks intended use. Every effort has been made to make the White Brothers forks very light and perform at a level superior to other forks on the market. To insure peak performance, proper installation and periodic maintenance is required. White Brothers forks are designed for off road use only. They are not equipped with reflectors for on road use. If you are going to use your fork on road, have a dealer or mechanic install reflectors that meet the Consumer Product Safety Commission's requirements. When riding on public land, please respect the rights of others and stay on established paths and trails. By riding responsibly, you are helping ensure the future of our wonderful sport.

# FORK INSTALLATION

White Brothers forks feature a 1-1/8" threadless steer tube. If you have a threaded type fork on your bicycle, consult your dealer for the appropriate upgrade parts necessary to convert to a 1-1/8" threadless steer tube.

1. Remove your old fork from the bicycle. Measure the diameter and length of your old fork's steerer tube to ensure that the White Brothers steerer tube is the correct diameter and sufficient length for the installation.
2. Remove the crown race from your old fork.
3. Press the crown race onto your new White Brothers fork (**see Figure #1**).
4. Preassemble the headset by sliding the fork steerer tube through the bearings. Then install the head set's upper race, headset spacer (optional), and stem onto the fork steerer tube. Adjust with optional spacers to your preferred height (**See Figure #2**). Refer to the head set owners manual if there is any questions about the preassemble.
5. Mark the steerer tube at the top of the stem. The steerer tube will now need to be cut to the correct length. Disassemble and cut 3mm (1/8") below the mark. Consult your dealer or mechanic if you don't have the proper tools to cut the steerer tube.
6. The star fangled nut must now be installed into the steerer tube. If you don't have the set tool we recommend dealer installation of this part (**See Figure #3**).
7. Clean and grease all headset bearings and races to prepare them for assembly. **Note:** Replace the bearings if there is any sign of wear or corrosion.
8. Now loosely assemble the headset, stem and handle bars as in step four.
9. Install the headset top cap into the star fangled nut. Tighten until there is no play in the steering. The fork should rotate freely in the head tube. Straighten the stem in relation to the front tire and tighten the pinch bolts on the stem. If there are any questions consult your dealer or mechanic.
10. Install your front brake and adjust according to the manufacturer's instructions.
11. Adjust the quick release on the hub to clear the secondary catches on the drop-outs. Tighten the quick release after the axle is properly seated in the drop-out. Ensure that there is sufficient thread engagement (5 or more threads with the quick release in the lock position) due to the thicker White Brothers drop-outs. Install the front wheel per manufacturer's specifications.
12. Check to see that the brakes are adjusted and properly working. Make sure the brake cable doesn't interfere with any part of the bike when the fork is compressed and released.

**Warning:** When installing the wheel or a new tire, check for minimum clearance. Measure from the highest point on the tire to the underside of the crown. There must be 1/8" or 3mm more clearance than the fork's travel to ensure adequate clearance in all riding conditions. Any less clearance can result in the tire hitting the crown resulting in serious injury or death.

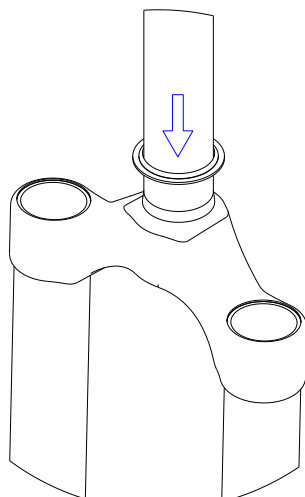

Figure #1

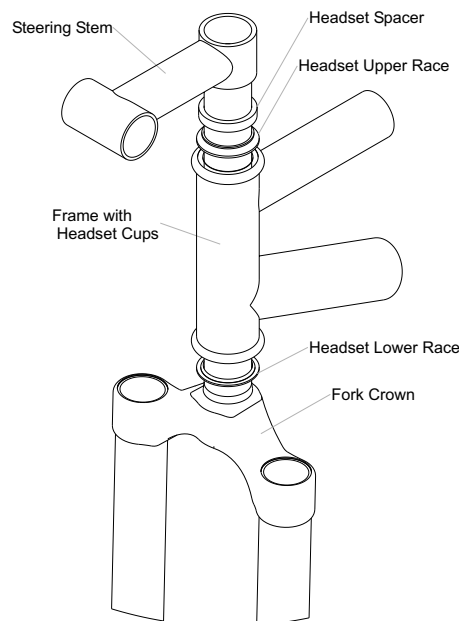

Figure #2

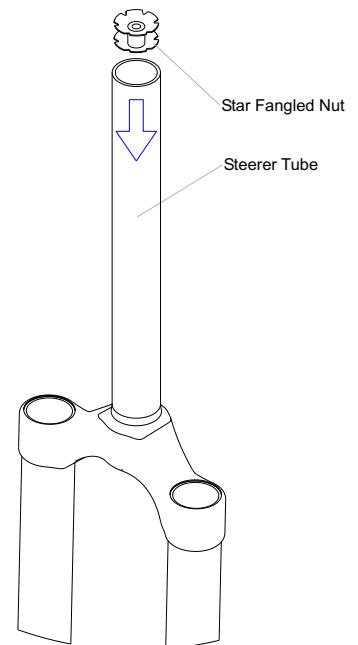

Figure #3

# TUNING

To get the most out of your White Brothers fork, it is important that you tune the fork to fit your riding style and the terrain you ride in.

## INITIAL BREAK-IN PERIOD:

Your new fork is designed to break-in over a period of 10 hours or more of riding. As all the parts bed into each other, the stiction (friction) of the fork decreases and the sensitivity increases. After the initial brake-in period, fine tuning the air pressure and damping adjustments may be beneficial to achieve the best possible performance for your weight and riding style.

## TOOLS NEEDED:

High pressure air pump (WB 97-725)  
 15/16" socket with ratchet.  
 4mm Allen Wrench  
 5mm Allen wrench

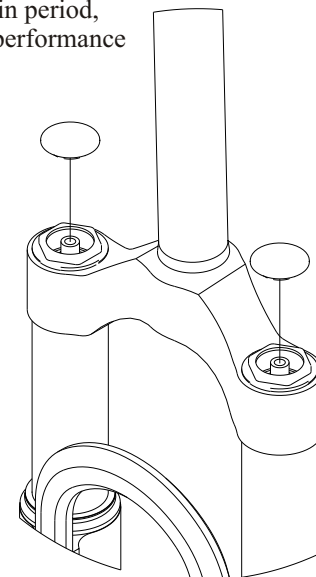

## AIR SPRING

Your new White Brothers fork is designed with dual air cartridges for air spring support and damping. The air cartridges are lightweight, adjustable air sprung shock absorbers that screw into the fork stanchion at the crown. The following guidelines for checking and adjusting your cartridges will enable you to enjoy maximum performance from your fork.

1. Test ride the fork over easy terrain. If after riding the fork over varied terrain you decide that more tuning is necessary, continue to the next step.
2. The compression or spring of the fork can be changed two ways: by changing air pressure in the cartridges and adjusting the settings of the air damper. If the fork feels too soft or firm, try changing the air pressure as follows: Remove the snap in dust cap (use a finger nail or small screw driver) so that the schrader valve stem is exposed (see Figure #4). A high pressure shock pump is necessary to inflate cartridges. Test ride after each adjustment until the air cartridges is at an adequate pressure. Reinstall the dust cap. NOTE: All pressures listed are a good starting point but pressures will vary depending on your riding style.

## AIR DAMPER

3. **Rebound Damping** is controlled by the size of a small hole in the side of the adjuster. There are four different adjusters marked blank (extra slow rebound) #1 (slow rebound), #2 (medium rebound) and #3 (fast rebound). The cartridge come with the #2 adjuster installed. See chart for recommended rebound adjuster.
4. To change the adjuster, deflate the cartridge. (**Warning- never remove the cartridge while inflated.**) Unscrew them from the legs using a 15/16" socket. Compress the cartridge by pushing the shaft into the body while holding the schrader valve open. Grasp the cartridge body firmly and unscrew the air cap from the body. **Do not remove the schrader valve to make adjustments.** Set the air cap on a clean and dust free surface. Unscrew the adjuster from the center of the piston using a 4mm allen wrench. Lift the adjuster out by tilting the allen key slightly and pulling it upward. Do not turn the cartridge upside down while the adjuster is removed as the valve and spring may fall out.
5. Insert the new adjuster into the piston. Push it down firmly to seat the o-ring. Start with the adjuster flush with the top of the piston and adjust down from there to set the compression damping (see step 6). Use the table as a starting point reference.

RECOMMENDED SETTINGS			
	Air Spring	Rebound Damping	Compression Damping
RIDER WEIGHT	CARTRIDGE PSI	ADJUSTER NUMBER	ADJUSTER SETTINGS "TURNS IN FROM FLUSH"
110	100ps i	#1	4 to 4.5
120	110ps i	#1	4.5 to 5
130	120ps i	#1	4.5 to 5
140	130ps i	#2	4.5 to 5
150	140ps i	#2	4.5 to 5
160	150ps i	#2	4.5 to 5
170	155ps i	#2	4.5 to 5
180	160ps i	#2	5 to 5.5
190	165ps i	#2	5 to 5.5
200	170ps i	#3	5 to 5.5
210	175ps i	#3	5 to 5.5
220	180ps i	#3	5 to 5.5

6. **Compression damping** tuning can be done by setting the depth of the adjuster in the piston. (See the table for recommended settings.) The cartridge comes with a #2 adjuster set at 9 ½ turns in from flush with the top of the piston.
7. To change the compression setting, deflate the cartridge. (**Warning- never remove the cartridge while inflated.**) Unscrew it from the left leg using a 15/16" socket. Compress the cartridge by pushing the shaft into the body while holding the schrader valve open. Grasp the cartridge body firmly and unscrew the air cap from the body. **Do not remove the schrader valve to make adjustments.** Set the air cap on a clean and dust free surface. Insert the long end of a 4mm allen wrench into the adjuster at the center of the piston. Unscrew the adjuster until it is flush with the top of the piston. Screw it back in, counting the turns, until you are at the setting recommended by Table #1. The closer to flush with the top of the piston, the softer it will feel, while more turns in will stiffen the compression damping. Fine tuning can be achieved by quarter turns.
8. Replace the air cap on the cartridge body and reinstall in the fork. Add air pressure until you are at the required pressure for your weight.

# MAINTENANCE

Your White Brothers fork requires periodic maintenance to ensure peak performance and long life. Neglecting proper maintenance will reduce the fork's life. Internal build up of water and dirt or a lack of lubrication will cause excessive wear and void the warranty.

**BEFORE EVERY RIDE:** Visually inspect your fork for bent or broken parts, loss of oil, abnormal sounds or other indications of possible fork failure. Compress you fork to verify proper function. Check all other bicycle components to ensure proper working order.

**AFTER EVERY RIDE:** Clean and dry the exterior of your fork. When cleaning the fork, do not direct the water spray at the seals. Visually inspect your fork for damage.

**\*EVERY 30 HOURS OF RIDING:** Your fork should be disassembled, inspected, cleaned and re-greased. If the fork appears to be relatively clean, you can go 40 hours between servicing. If the fork appears excessively dirty you should service it every 20 hours. The three things that will effect the service interval and performance of your fork are water, mud and dust. How much you use your fork in those conditions will determine how much service it requires.

**\*EVERY 100 HOURS OF RIDING:** Complete service should include removing the lower fork legs and cleaning and re-greasing all shafts, bushings and seals. Check top cap assemblies, damper cartridge, stanchion plug, brake post bolts and shaft bolts for proper torque. At this time, the fork should be carefully inspected for wear and damage before reassembly. Contact White Brothers for replacement parts and service. We recommend that this service be performed by a certified White Brothers service center or by the factory.

\*White Brothers recommends that you consult with a qualified technician for major service.

## Maintenance (Air Cartridge)

1. Once a year (depending on riding style and frequency) the cartridge should be removed for annual maintenance. **Deflate the cartridge.** Unscrew the cartridge from the stanchion tube.
2. Remove the air cap from the cartridge body and push the shaft and piston assembly out the top of the cartridge. Inspect the air cap o-ring and piston o-ring for damage or dirt. If the o-rings are damaged see your local dealer or contact White Brothers for o-ring rebuild kit. Clean and lubricate the o-rings and shaft with Slick Honey. Re-assemble the cartridge. When inserting the shaft in the body, push the shaft end through the o-rings with a steady, gradual push so that the o-ring is not damaged. Replace the air cap on the body, making sure it is snug but not over tightened. Inflate the cartridge to 150 psi outside the fork and immerse in water. Check for any slow bubbling from around the air cap or where the shaft enters the cartridge body. If you see bubbling consult the trouble shooting section.

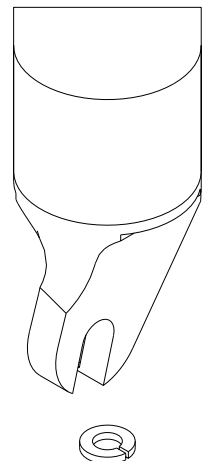

## Basic Fork Disassembly and Inspection

1. Disconnect the front brake and remove the wheel as outlined in you bicycle owners manual. **Important:** Pop the cap off the air side and **deflate the cartridge (See Figure #4).**
2. Loosen the allen bolts at the bottom of the fork legs (**See figure #5**). A light tap may be need to free the control rod from the lower assembly. Finish removing the screws.
3. Simply slide the fork legs off the end of the inner stanchion tubes. Be careful not to damage the seals as they come off the inner legs.

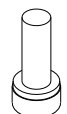

**Figure #5**

4. Clean all parts with a clean, non-abrasive rag. A mild grease cutting cleaner or solvent might make this an easier task. Once clean, inspect the seals for tears or cracks. If okay, re-grease them with Suspension Lube. If your seals show signs of wear see the exploded diagram for replacement part numbers.
5. Check the DU bushings carefully for wear. If there is noticeable movement back and forth when the legs are fully engaged on the fork stanchions, the DU bushings may need to be replaced. Please note that special tools are required to remove and replace these bushings. This service can be performed by White Brothers.
6. Next, inspect the fork stanchion tubes for wear, nicks or scrapes. These will cause premature wear on the seals and DU bushings. Check again for noticeable play between the stanchion tubes and the fork lower.
7. If everything is free of problems, coat all parts with a light coat of Suspension lube. Be sure to lube the DU bushings located inside the lower legs.

## Basic Fork Assembly

1. Make sure all the spacers are installed on the control rods (see exploded views for proper installation) and the bottoming o-rings are in the bottom of the legs. Make sure the fork cap and cartridge are fully tightened into the top of the stanchion tubes. With all parts cleaned and reinstalled with new grease, fit the lower assembly over the stanchion tubes and gently rock and slide together until the control rods are touching the bottom of the lower assembly. Thread the compression screws into the control rods and firmly tighten. Adding air to the air cartridge may be needed to push the control rod down to the bottom of the leg. This will also help hold the rod from spinning as you tighten the compression screw on the air side. **Note: Ensure the compression screws are fully tight before riding.**
2. Connect the front brake and wheel as outlined in you bicycle owner's manual.
3. Compress the fork to make sure it works smoothly and the brake cable doesn't foul on the fork in any way.

# TROUBLE SHOOTING

## Loss of Air Pressure (in excess of normal seepage)

Deflate the cartridge and unthread it from the left stanchion tube. Re-inflate the cartridge to 150 psi and immerse in water for several minutes with the dust cap removed. Check for any slow bubbling.

1. Check the tightness of the air cap on the body. It should be a firm hand tight but not over tight.
2. Check the o-rings for damage, a fiber, hair or large dirt particle. Slow bubbling for inside or underneath the air cap usually indicates a contaminated air cap o-ring. Remove suspect o-rings with a toothpick. If the o-ring is not cut or torn, cleaning and re-greasing the o-ring usually repair the leak.
3. Check the valve core for bubbles. Tighten the valve core with a valve core wrench if you see any leakage. If not replace the valve core.
4. If no leak can be seen after one minute of immersion, pressure loss probably occurs in use due to a worn or contaminated cartridge body o-ring. If leakage is visible, body o-ring is easy to replace with a "Cartridge Body Seal Kit" available through your local dealer or from White Brothers.
5. If none of these remedies solve the problem contact White Brothers for technical support.

## Loss of Rebound Damping

Deflate the cartridge, remove the cartridge from the fork and remove the air cap. Make sure the adjuster, compression valve and spring are intact, clean and assembled correctly in the piston. If these parts are clean and properly installed, loss of damping is probably due to a worn piston o-ring. Contact your dealer or White Brothers for an o-ring rebuild kit.

## Fork Feels Sticky

This is usually caused by:

1. A lack of lubrication. Clean and lubricate the fork as outlined in the maintenance section.
2. Contamination inside the fork. Clean and lubricate the fork as outlined in the maintenance section.
3. Fork is not sufficiently broken in. Contact White Brothers for further technical information.

## The Fork Bottoms Too Easily

1. Incorrect air pressure. Add air pressure as outlined in the tuning section.
2. Insufficient compression damping. Add compression damping by turning the adjuster as out lined in Table #1.

## The Fork Doesn't Use Full Travel

1. Incorrect air pressure. Remove air pressure as outlined in the tuning section.
2. Excessive compression damping. Reduce the compression damping by turning the adjuster as outline in Table #1.

## Exploded Views

The following is an illustration and parts table which gives you the exploded view of your White Brothers fork. The parts table indicates the part numbers for each individual part in the fork.

Reference these numbers when ordering replacement parts. See your local dealer or contact White Brothers to order the parts you require.

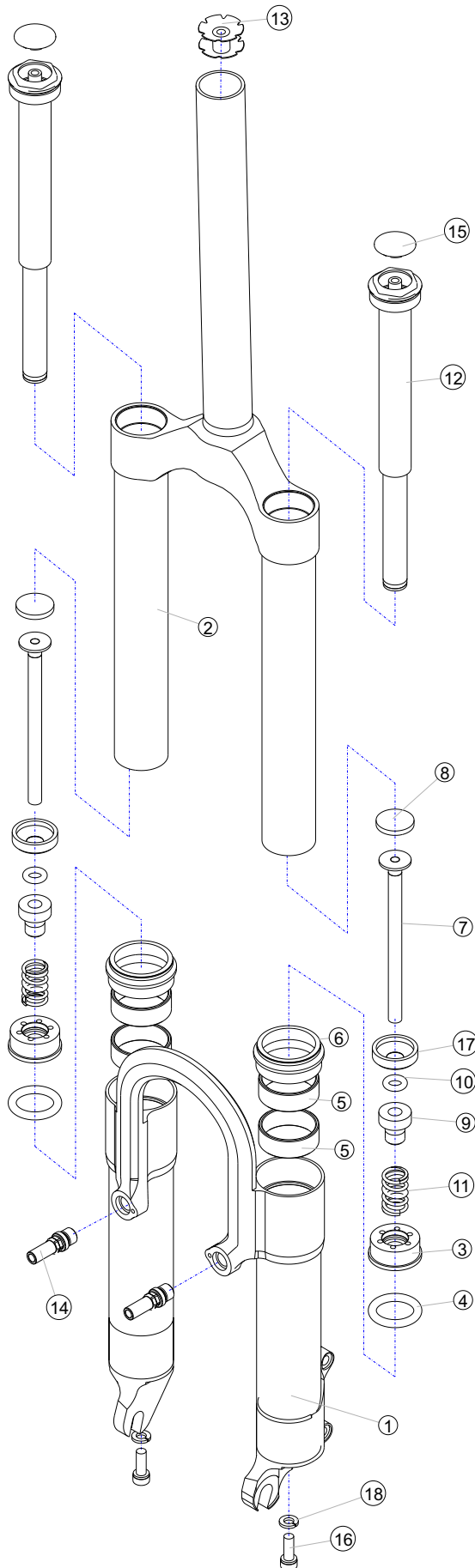

### RC Air Fork W/ Air Damping

ITEM NO	QTY	PART NO.	DESCRIPTION
1	1	RC .8 Lower Assembly	RC .8 Lower Assembly
2	1	RC .8 Upper Assembly	RC .8 Upper Assembly
3	2	97-3561-1	Stanchion Plug
4	2	100009	Bottomout O-Ring
5	4	97-986	DU Bushing
6	2	97-1351	Wiper Seal
7	2	Control Rod	Control Rod
8	2	ZTA-PAD	Compression Pad
9	2	P3319-1	Negative Spring Guide
10	2	ZTA-ORING-203	O-Ring 203
11	2	ZTA-SPRING2RAW	Negative Spring
12	2	TA-C-WBRC275	RC TA Air Cartridge
13	1	97-9301	Star Nut
14	2	97-3668	Thread In Brake Boss
15	2	P4650	Dust Cap
16	2	ZTA-J-SCREW	Compression Screw 6mm x 16
17	2	P2504	Pad Holder
18	2	ZTA-J-WASHER	Lock Washer

Owner's Name: \_\_\_\_\_  
 Address: \_\_\_\_\_  
 Phone: \_\_\_\_\_  
 Purchase Date: \_\_\_\_\_  
 Purchase Location: \_\_\_\_\_  
 Serial #: Located on lower back side of right axle clamp. \_\_\_\_\_

# MAINTENANCE LOG

Date	Service Performed

Date	Service Performed

# WARRANTY CLAIMS

White Brothers forks are the highest quality and as such are warranted to be free from defects in materials and workmanship for a period of one year from the date of purchase for the original purchaser. On receipt of the fork, if it is found to be defective, White Brothers will determine replacement or repair of the fork. This warranty is the sole and exclusive remedy. White Brothers shall not be liable for any indirect, special or consequential damages. Warranty does not apply to any product that has been installed improperly or adjusted using methods not outlined in this manual. Warranty also does not cover forks that have been misused, or forks that have missing/altered serial numbers (located on the back of the right fork stanchion). The fork is not warranted against damage in the appearance of the fork or for modifications not outlined in this manual. This warranty does not cover breakage, bending, or damage that may result from crashes, falls or abuse. Normal wear (i.e. seals, bushings, slider finish, etc) and wear and damage caused by lack of proper maintenance is not included. **\*The warranty registration card must be filled out and returned within 30 days of purchase to activate and validate this warranty.** A copy of the proof of purchase must be included with all warranties. Customers in the USA please contact your dealer for a Return Authorization Number (RA#) before returning the forks. All forks returned for inspection must be sent freight paid to:



580 N. Westgate Dr.  
 Grand Junction, CO 81505 USA  
 1.800.999.8277  
 www.whitebrotherscycling.com

